

GENERAL SCIENCE

Class X Standard – CBSE

Solution to Set - 1

SECTION – A

1. Aluminium displaces hydrogen from strong caustic alkalies to form its oxide.

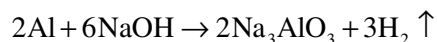

2. $\text{CaO}(\text{s}) + \text{H}_2\text{O}(\text{l}) \rightarrow \text{Ca}(\text{OH})_2(\text{aq})$. Chemical combination reaction.

3. It is formed by the reaction between a strong acid and a weak base.

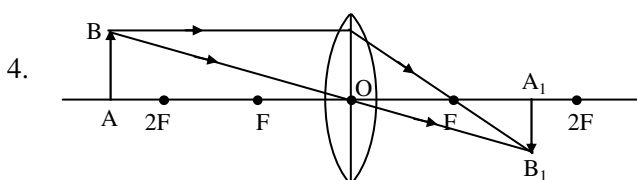
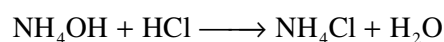

Image is real, inverted, diminished and is formed between F and 2F.

5. Purpose of earthing the metallic body of an electrical appliance is to conduct away the electricity, if leaked into the body of the appliance, so that we can save ourselves from electric shocks.
6. An incandescent lamp operates at a temperature of 2700°C , whereas the melting point of tungsten is about 3400°C .
7. An aqueous solution of acid like HCl conducts electricity because it ionizes to form H^+ and Cl^- ions. These ions will conduct electricity.

Take an aqueous solution of HCl as electrolyte in an electrolytic cell. The bulb glows when the switch is on. This proves that acid in aqueous medium conducts electricity.

8. (a) $3\text{BaCl}_2 + \text{Al}_2(\text{SO}_4)_3 \rightarrow 3\text{BaSO}_4 \downarrow + 2\text{AlCl}_3$.

(b) Silver chloride (white) turns grey in sunlight. It forms silver and chlorine by photodecomposition.

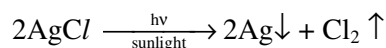

9. Solenoid is a long coil containing a large number of close turns of insulated copper wire.

When electric current is passed through the solenoid, it produces a magnetic field around it.

The magnetic lines of force inside the solenoid are in the form of parallel straight lines.

This indicates that the strength of magnetic field is the same at all the points inside the solenoid.

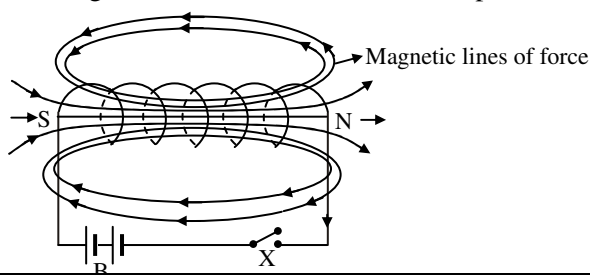

10. A continuous conducting path consisting of wires resistance (like electric bulb) and a switch between the 2 terminals of a cell or a battery along with flow of electric current is called a circuit.

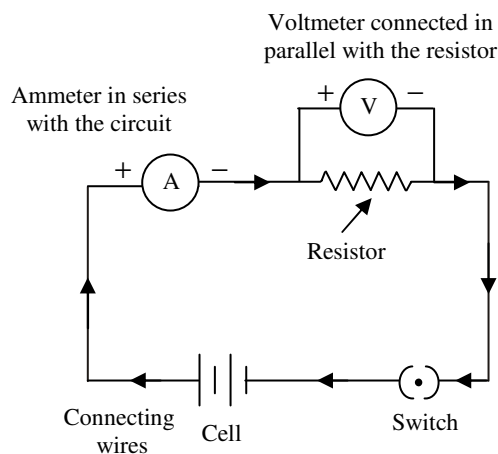

11. (a)

Group 1 elements	Atomic radii (pm)
Li	152
Na	186
K	231
Rb	244
Cs	262

- (b) The element lithium has the smallest atom whereas cesium has the largest atom.
- (c) It can be concluded that the atomic size of elements increases as we go down the group.
12. (a) When copper metal which is low in the reactivity series can be extracted just by heating its sulphide ore(Cu_2S) in the air.
- (i) When copper (I) sulphide is heated in a current of air, a part of it is oxidised to copper (I) oxide.
- $$2\text{Cu}_2\text{S}(\text{s}) + 3\text{O}_2(\text{g}) \xrightarrow{\text{Heat}} 2\text{Cu}_2\text{O}(\text{s}) + \text{SO}_2(\text{g})$$
- (ii) When O_2 supply is stopped Cu_2O reacts with remaining Cu_2S to form copper metal and sulphur dioxide.
- $$2\text{Cu}_2\text{O}(\text{s}) + \text{Cu}_2\text{S} \xrightarrow{\text{Heat}} 6\text{Cu}(\text{s}) + \text{SO}_2(\text{g})$$
- (b) The surface of aluminium metal is covered with a thin layer of oxide that helps protect the metal from attack by air.
13. (a) When the sun is overhead at noon, the light from the sun has to travel a shorter distance. Only a little of the blue colour of white light is scattered (most of the blue light remains in it). Since light reaching coming to us has almost all the component colours in the right proportion, the sun in the sky appears white to us.
- (b) The scattering of light by particles in its path is called Tyndall effect.

When a beam of sunlight enters a dusty room through a window, then its path becomes visible to us.

This is, because, the tiny dust particles present in the air scatter the beam of light.

When this scattered light enters our eyes, we can see the beam of light.

14. Here, $R_1 = 5\Omega$, $R_2 = 10\Omega$ and $R_3 = 30\Omega$.

(a) All the resistances are connected in parallel. If R be their equivalent resistance, then we have,

$$\frac{1}{R} = \frac{1}{R_1} + \frac{1}{R_2} + \frac{1}{R_3} = \frac{1}{5\Omega} + \frac{1}{10\Omega} + \frac{1}{30\Omega}$$

$$\Rightarrow \frac{1}{R} = \frac{6+3+1}{30\Omega} = \frac{1}{3\Omega} \Rightarrow R = 3\Omega$$

(b) The total potential difference applied in the circuit is $V = 12V$. Also, the total resistance in the circuit $R = 3\Omega$. Hence, the total current in the circuit, by Ohm's law, is $i = \frac{V}{R} = \frac{12V}{3\Omega} = 4A$

(c) Let the currents through the resistances R_1 , R_2 and R_3 be i_1 , i_2 and i_3 respectively.

Then, by using Ohm's law, we have

$$i_1 = \frac{V}{R_1} = \frac{12V}{5\Omega} = 2.4A, \quad i_2 = \frac{V}{R_2} = \frac{12V}{10\Omega} = 1.2A,$$

$$i_3 = \frac{V}{R_3} = \frac{12V}{30\Omega} = 0.4A.$$

The total current in the circuit is $i = i_1 + i_2 + i_3 = 2.4A + 1.2A + 0.4A = 4A$.

15. (a) This is because Ca^{2+} and Mg^{2+} present in hard water react with the long chain carboxylic acid group present in the soap to form insoluble scum (calcium or magnesium stearate) which sticks to the hair.

(b) (i) Ethanoic acid reacts with absolute ethanol in the presence of an acid catalyst to give an ester .

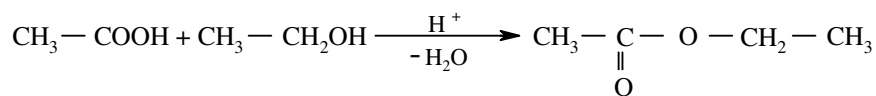

(ii) Ethanoic acid reacts with Na_2CO_3 to give a salt, CO_2 and H_2O .

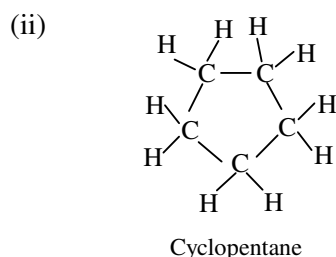
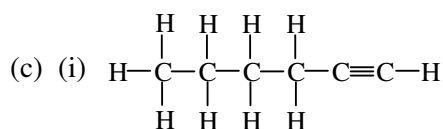
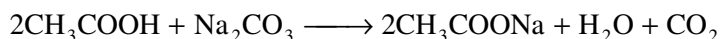

Or

(a) The holes provide sufficient air (i.e., oxygen) for the complete combustion of LPG.

If the holes are blocked, there is insufficient supply of air which leads to the incomplete combustion of LPG.

- (b) The molecular formula of compound x is C_2H_6O . It can either be CH_3CH_2OH (ethyl alcohol) or CH_3OCH_3 (methoxy methane).

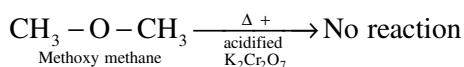
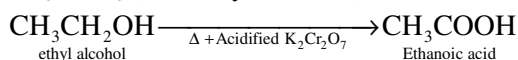

\therefore the compound X is ethyl alcohol and the compound Y is ethanoic acid.

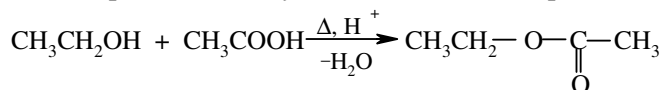

The compound Z is ethyl ethanoate. Ethyl ethanoate

- (c) (i) Alcohol: $-OH$

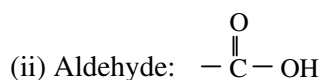

16. (a) Characteristics of image: Image is real, inverted same size as the object and is formed at C, in front of the concave mirror.

Given $h = 2$ cm, $h_i = 3$ cm, $u = -8$ cm

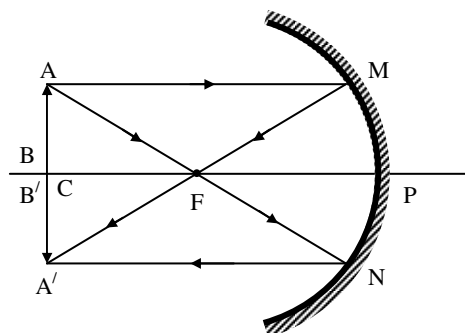

- (b) (i) To calculate the position of the image

$$\frac{h_i}{h_o} = -\frac{v}{u} \quad \{\text{As image is virtual } h_i = 3 \text{ cm is +ve } u \text{ is always negative}\}$$

$$\Rightarrow v = \frac{-uh_i}{h_o} = \frac{(-8) \times 3}{2} = 12 \text{ cm}$$

Thus, image is formed 12 cm behind the mirror.

- (ii) To calculate the focal length

$$\frac{1}{f} = \frac{1}{u} + \frac{1}{v} \quad \{u = -8 \text{ as } u \text{ is always negative, } v = +12 \text{ as } v \text{ is +ve for virtual image}\}$$

$$\Rightarrow \frac{1}{f} = \frac{1}{-8} + \frac{1}{12} \Rightarrow \frac{1}{f} = \frac{-3+2}{24} \Rightarrow \frac{1}{f} = \frac{-1}{24} \therefore f = -24 \text{ cm}$$

Thus, the focal length of the converging mirror is -24 cm.

- (c) (i) Convex mirrors are used as rearview mirrors as they produce erect, diminished image of the object and also give wide view of traffic behind.
(ii) A concave mirror, as it diverges the rays of light when bulb is between P and F.

Or

- (a) Characteristics of image: Image is real, inverted, enlarged and formed between C and infinity, in front of the concave mirror.

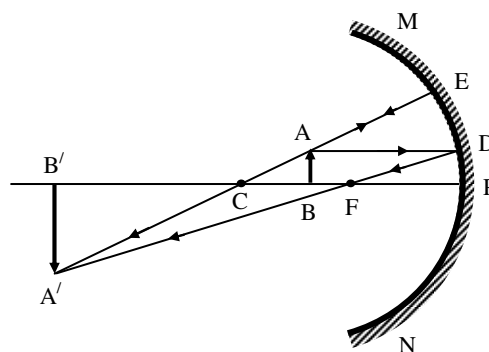

(b) Focal length of concave lens (f) = -15cm

Distance of object from lens (u) = ?

Distance of the image from the lens (v) = -10cm $h_0 = 10\text{ cm}$

$$\text{Applying, } \frac{1}{v} - \frac{1}{u} = \frac{1}{f} \Rightarrow \frac{1}{-10} - \frac{1}{u} = \frac{-1}{15} \Rightarrow \frac{-1}{10} + \frac{1}{15} = \frac{1}{u} \text{ or } \frac{1}{u} = \frac{1}{15} - \frac{1}{10} = \frac{2-3}{30} = \frac{-1}{30} = u = -30\text{ cm}$$

$$\text{Also, } \frac{h_i}{h_0} = \frac{v}{u}$$

$$\frac{h_i}{10} = \frac{-10}{-30}$$

$$h_i = \frac{-10 \times 10}{-30} = 3.33\text{ cm}$$

Thus, virtual, erect and diminished image is formed on the same side as the object.

(c) The coin placed under water appears to be raised due to refraction of light.

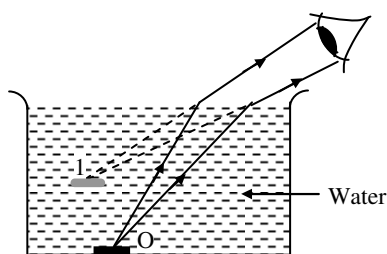

SECTION – B

17. The movement of leaves in the sensitive plant is a type of nastic movement which is directed neither towards nor away from the stimulus. The movement of shoot towards light is a tropic movement directed towards the stimulus or away from it.
18. Grass will transfer maximum energy as it produces food utilising sun's energy. There is no loss of energy to the atmosphere according to ten percent law as it is the first trophic level.
19. Scrotum provides optimal temperature for formation of sperms. Vas deferens carries sperms into seminal vesicles where they are nourished.
20. (a) Large areas of agricultural land and human habitations are submerged in the water of reservoir formed by the dam.
(b) The vegetation submerged under water of the reservoir of dam rots under anaerobic conditions to produce large amount of methane which is a green house gas.
21. The amount of ozone is getting depleted due to which the ozone layer in the upper CFCs released into the air react with ozone gas present in the ozone layer and destroy it gradually. Depletion of ozone layer allows more ultraviolet rays to pass thro it to the earth. V.V rays can cause skin cancer, cataract and damage immune system.
22. For a trait of an organism to be inherited, it should bring about a change in the genes (DNA) present in the reproductive cells of that organism.

The traits acquired during the life–time of a person do not bring about a change in the genes (or DNA) present in its reproductive cells and hence they are not inherited by the off springs.

23. Amoeba obtains nutrition by putting forth finger like projections called pseudopodia which fuse over the food particle forming a food – vacuole.

Inside the food – vacuole, complex substances are broken down into simpler ones which then diffuse into the cytoplasm.

The remaining undigested material is moved to the surface of the cell and thrown out.

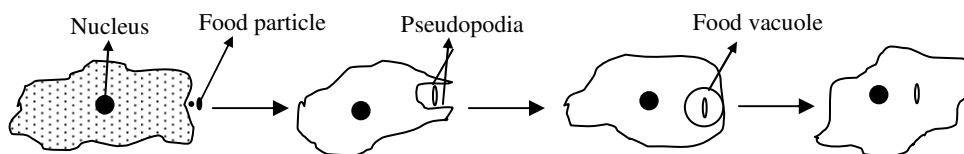

24. Sometimes, the kidneys may be damaged due to infection, injury, restricted blood flow diabetes and extremes of blood pressure.

The damaged kidney will not be able to remove nitrogenous waste products.

To maintain H₂O and ionic balance and to remove metabolic wastes, an artificial kidney is employed.

The procedure used in an artificial kidney is called dialysis.

25. Recycling: Few waste materials can be recycled back to make useful things.

Eg: Plastic, glass

Reducing: The consumption of natural resources can be reduced by using them less.

Eg.: Electricity, water, petrol etc.

Reusing: Some waste materials can be reused over and over again.

Eg: Envelopes may be reversed and used again.

26. Digestion of proteins.

Mouth: No digestion as amylase does not act on proteins.

Stomach: Pepsin in an acidic medium acts on proteins and breaks them into smaller molecules.

Small intestine: Pancreatic juice secretes few enzymes trypsin acts on remaining proteins and converts them into smaller molecules.

Intestinal juice secretes enzymes which convert all the proteins into amino acids.

27. (a)

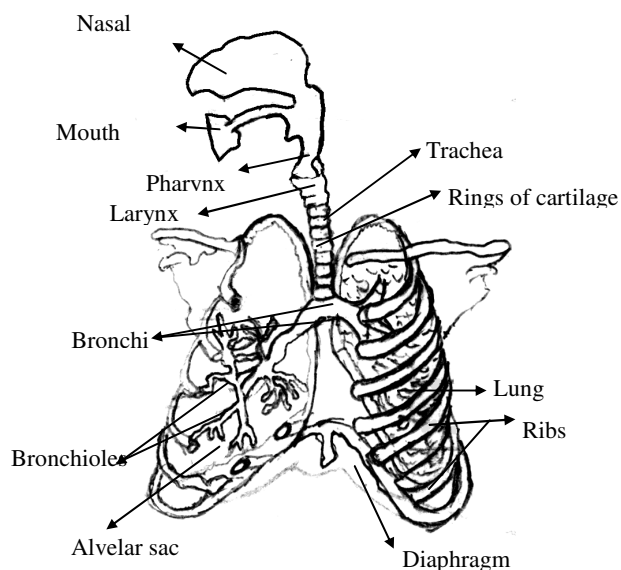

(b) Alveoli – Help in exchange of gases – O₂ and CO₂

Mucus – Filters the air entering the nose during inhalation.

(c) Cartilagenous rings prevent the trachea from collapsing when there is insufficient supply of air in trachea.

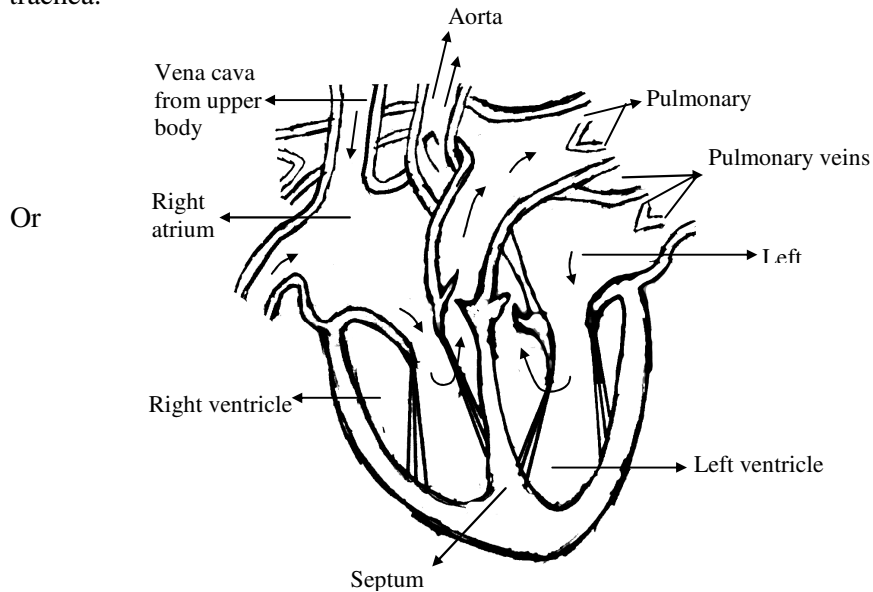

(b) This is because it is useful in animals that have high energy needs, which use energy constantly to maintain their body temperature.

(c)

Arteries		Veins	
(i)	They carry oxygenated blood from the heart to various parts of the body.	(i)	They carry deoxygenated blood from various parts to the heart.
(ii)	They are thick walled as blood flows under high pressure	(ii)	They are thin walled as blood flow under less pressure.

* * *